

## NOSE ASSEMBLY (G-882 MARINE MAGNETOMETER)

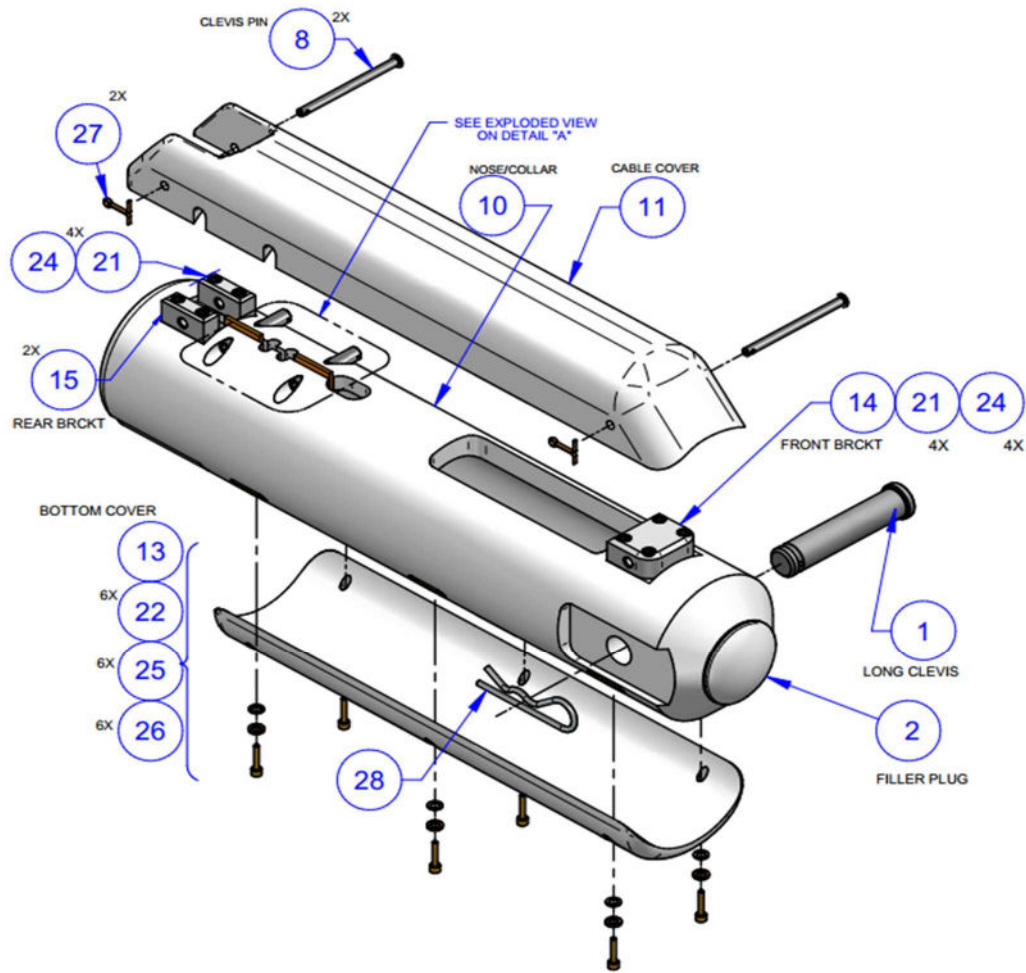

Item	Item Number	Item Name	Quantity
REF	<b>820-00421-01</b>	<b>G-882 NOSE ASSEM. NO ALTIM.</b>	
2	340-00096-01	G-882 FILLER PLUG	1
10	340-00086-02	G-882 NOSE/COLLAR	1
11	340-00095-01	G-882 CABLE COVER-TALL	1
13	340-00097-01	G-882 BOTTOM COVER	1
14	330-00211-01	FRONT BRACKET, G-882 CABLE COVER	1
15	330-00211-02	REAR BRACKET, G-882 CABLE COVER	2
		<b>List continues on next page</b>	

All drawings, designs, text, graphics, and other materials provided on this website (the "Site") (collectively, "Content") is owned, controlled, or licensed by or to Geometrics, Inc. ("Geomertics"), and is protected by copyright, patent and trademark laws, and various other intellectual property rights and unfair competition laws.

Except as expressly provided in a written agreement between you and Geometrics, no part of this Site and no Content may be reproduced or used by you in any manner for manufacture of any assembly, sub-assembly or part indicated herein or any design indicated herein, and no part of the Site or Content may be copied, reproduced, republished, uploaded, posted, publicly displayed, encoded, translated, transmitted or distributed in any way without express written permission of Geometrics.

The only limited use you may make of the information about Geometrics products and services (such as drawings, knowledge base articles, and similar materials) purposely made available by Geometrics for downloading from this Site is for your informational purposes in connection with your company's authorized use of Geometrics products and services, and provided that you (1) do not remove any proprietary notice language in all copies of such information/documents, (2) make no modifications to any such information/documents, and (3) do not make any representations or warranties relating to such information/documents.

## NOSE ASSEMBLY (G-882 MARINE MAGNETOMETER) CONTINUED:

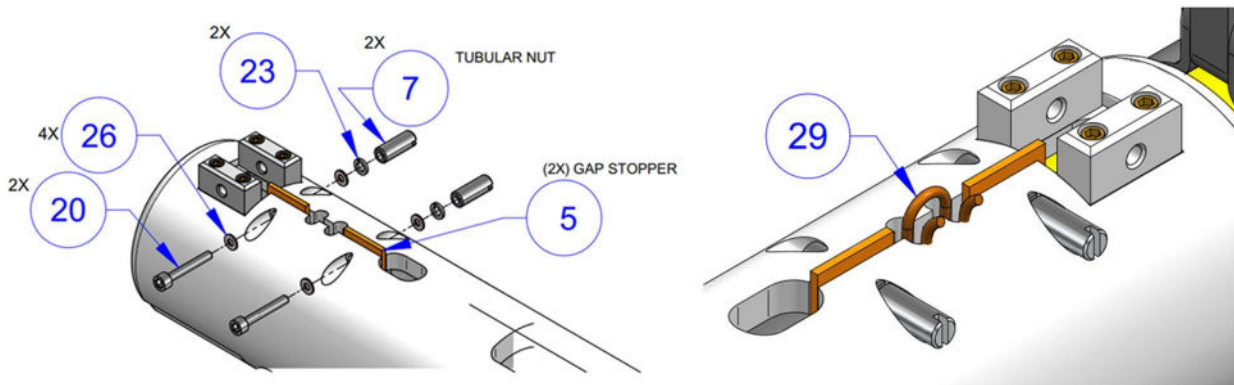

Item	Item Number	Item Name	Quantity
★	<b>870-00228-01</b>	<b>G-882 NOSE ASSEM. NO ALTIM_HARDWARE ONLY_KIT</b>	<b>See Below</b>
1	330-00104-01	LONG CLEVIS PIN	1
5	340-00069-02	GAP STOPPER, G-882 NOSE, .100	2
7	330-00180-01	TUBULAR NUT, G-882 NOSE/COLLAR	2
8	330-00182-01	CLEVIS PIN, G-882 CABLE COVER	2
20	470-00201	SCREW, 10-32X1.125 SKTHD 316SS	2
21	470-00279	MagScreen, SCREW,6-32X5/8 HEX SKT HD BRS	8
22	470-00280	MagScreen, SCREW,10-32X.75IN HEX SKT HD BRS	6
23	495-00027	WASHER, LOCK #10 316SS	2
24	495-00042	WASHER, SPLIT LOCK #6 BRONZE	8
25	495-00046	WASHER, SPLIT LOCK #10 BRONZE	6
26	495-00074	WASHER,NYLON ,FLAT. .312 X .190 X .032,(#10)	10
27	445-00057	MagScreen, COTTER PIN 1/16X3/4" 316SS	2
28	445-00103	316SS HAIRPIN CLIP FOR LONG CLEVIS PIN	1
29	467-00016	TRIMMER LINE .095"DIA BRIGHT ORANGE	1.5

All drawings, designs, text, graphics, and other materials provided on this website (the "Site") (collectively, "Content") is owned, controlled, or licensed by or to Geometrics, Inc. ("Geomertics"), and is protected by copyright, patent and trademark laws, and various other intellectual property rights and unfair competition laws.

Except as expressly provided in a written agreement between you and Geometrics, no part of this Site and no Content may be reproduced or used by you in any manner for manufacture of any assembly, sub-assembly or part indicated herein or any design indicated herein, and no part of the Site or Content may be copied, reproduced, republished, uploaded, posted, publicly displayed, encoded, translated, transmitted or distributed in any way without express written permission of Geometrics.

The only limited use you may make of the information about Geometrics products and services (such as drawings, knowledge base articles, and similar materials) purposely made available by Geometrics for downloading from this Site is for your informational purposes in connection with your company's authorized use of Geometrics products and services, and provided that you (1) do not remove any proprietary notice language in all copies of such information/documents, (2) make no modifications to any such information/documents, and (3) do not make any representations or warranties relating to such information/documents.