

G-882 COUNTERWEIGHT ASSY WITH HANDLE/RAILS

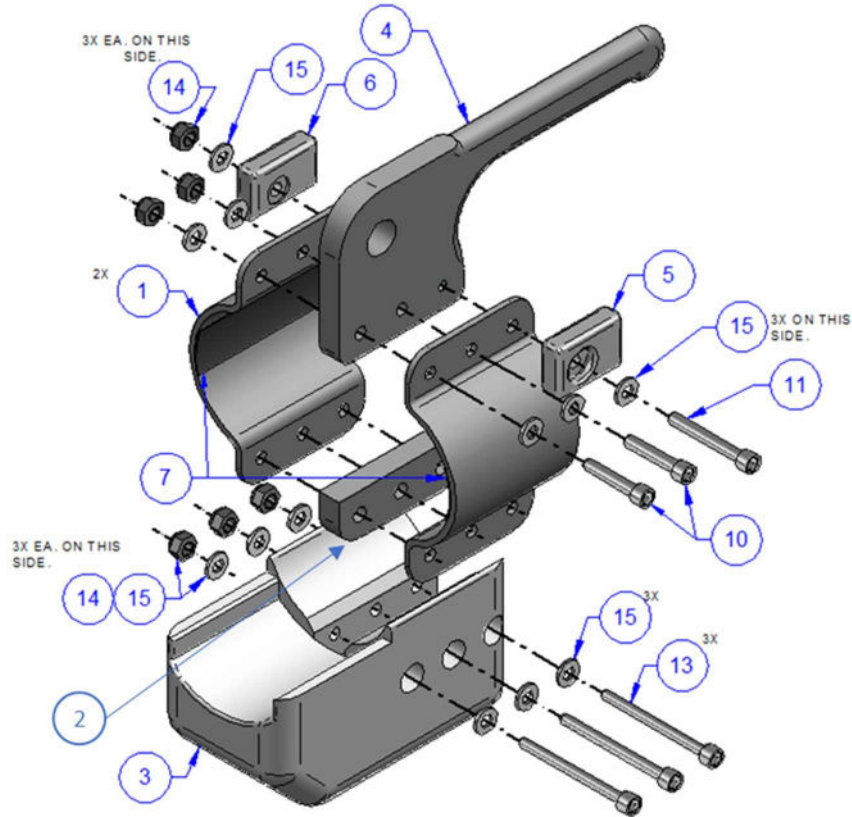

ASSY EXPLODED VIEW

Item	Item Number	Item Name	Quantity
REF	820-00434-03	G-882 COUNTERWEIGHT ASSY WITH HANDLE/RAILS	
1	340-00092-11	SMALL CLAMP-HALF	2
2	330-00192-03	SHIM-03	1
3	330-00205-02	G-882 Painted CounterWeight W/Rails	1
4	330-00206-01	GRAB HANDLE,G-882	1
7	820-00456-04	CUSHION SHEET, G-882 C'WEIGHT CLAMP	2
★	870-00230-01	G-882 COUNTERWEIGHT ASSY_HARDWARE ONLY_KIT	See Below
5	820-00449-01	ZINC ANODE, LEFT HANDLE	1
6	820-00449-02	ZINC ANODE, RIGHT HANDLE	1
10	470-00197	SCREW, SKTHD,1/4-20X1.25 316SS	2
11	470-00199	SCREW SOCKET HD CAP 1/4-20X1.75 SS	1
13	470-00200	SCREW SOCKET HD CAP 1/4-20 X 2.50 316 SS	3
14	450-00054	NUT STOP 1/4-20 316SS	6
15	495-00011	SMALL DIA FLAT WASH 1/4 IN 300 SERIES SS	12

All drawings, designs, text, graphics, and other materials provided on this website (the "Site") (collectively, "Content") is owned, controlled, or licensed by or to Geometrics, Inc. ("Geometrics"), and is protected by copyright, patent and trademark laws, and various other intellectual property rights and unfair competition laws.

Except as expressly provided in a written agreement between you and Geometrics, no part of this Site and no Content may be reproduced or used by you in any manner for manufacture of any assembly, sub-assembly or part indicated herein or any design indicated herein, and no part of the Site or Content may be copied, reproduced, republished, uploaded, posted, publicly displayed, encoded, translated, transmitted or distributed in any way without express written permission of Geometrics.

The only limited use you may make of the information about Geometrics products and services (such as drawings, knowledge base articles, and similar materials) purposely made available by Geometrics for downloading from this Site is for your informational purposes in connection with your company's authorized use of Geometrics products and services, and provided that you (1) do not remove any proprietary notice language in all copies of such information/documents, (2) make no modifications to any such information/documents, and (3) do not make any representations or warranties relating to such information/documents.